

POWER HEADERS, STACKERS & SOCKETS

MAX
16.
A m p s

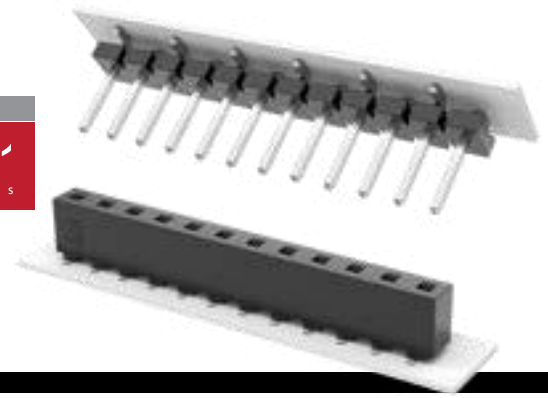

(5.08 mm) .200" PITCH • HPM, HPW, HPF SERIES

HPM, HPW

Board Mates:
HPF

HPF

Board Mates:
HPM, HPW

SPECIFICATIONS

Insulator Material:
HPW/HPM = Glass Filled Polyester (Through-hole), Natural Liquid Crystal Polymer (Surface Mount)
HPF = Black LCP
Terminal Material (HPM/HPW):
Copper Alloy
Contact Material (HPF):
BeCu
Plating:
Sn over 50 μ" (1.27 μm) Ni
Operating Temp Range:
-55 °C to 90 °C

Voltage Rating:
HPM/HPF = 850 VAC/1200 VDC

Insertion Depth (HPF):
(3.68 mm) .145" to (8.26 mm) .325" (.368" (9.35 mm) plus board thickness minimum for bottom entry)

Wiping Distance (HPF):
(0.38 mm) .015"

PROCESSING

Lead-Free Solderable:
HPW-VS, HPM-VS, HPF = Yes
HPM -TH, HPM -RA & HPW -TH = No, Lead Wave only
SMT Lead Coplanarity:
HPM = (0.20 mm) .008" max (02-15)*
HPW = (0.25 mm) .010" max (02-15)*
HPF = (0.20 mm) .008" max*

HPF = (0.15 mm) .006" max (02-10)*
(0.20 mm) .008" max (11-20)*
*(.004" stencil solution may be available; contact ipg@samtec.com)

Note:
Some lengths, styles and options are non-standard, non-returnable.

HPM	NO. OF PINS	LEAD STYLE	PLATING OPTION	S	TAIL OPTION	OTHER OPTION
-----	-------------	------------	----------------	---	-------------	--------------

High Temp High Power Header

01 thru 20

Specify LEAD STYLE from chart below

-T = Matte Tin

Leave blank for Through-hole
-RA = Right-angle (-02 & -04 lead style only)
-VS = Surface Mount (2 pins/row minimum) (-01 & -02 lead style only)

-P = Pick & Place Pad (3 Pos. min.) (-VS only) (Not Available with -05 lead style)

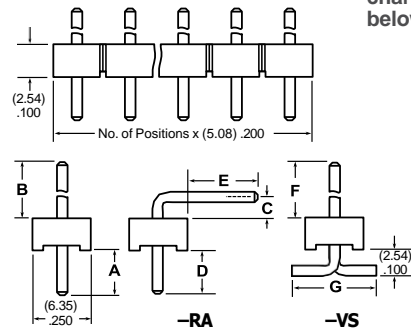

LEAD STYLE	A	B	C	D	E	F	G
-01	(4.57) .180	(11.94) .470	-	-	-	(10.72) .422	(8.64) .340
-02	(4.57) .180	(13.21) .520	(2.54) .100	(4.57) .180	(8.08) .318	(12.24) .482	(8.38) .330
-04	(4.09) .161	(21.06) .829	(4.95) .195	(3.96) .156	(13.82) .544	-	-
-05	(4.57) .180	(3.81) .150	-	-	-	-	-

HPW	NO. OF PINS	04	PLATING OPTION	S	STACK HEIGHT	POST HEIGHT	OTHER OPTIONS
-----	-------------	----	----------------	---	--------------	-------------	---------------

High Temp High Power

02 thru 20

-T = Matte Tin

-“XXX” = Stacker Height (in inches) (0.13 mm) .005" increments

-“XXX” = Post Height (in inches)

Leave blank for Through-hole
-VS = Surface Mount (2 pins/row minimum)

-P = Pick & Place Pad (3 Pos. min.) (6.98 mm) .275" max. post height (-VS only)

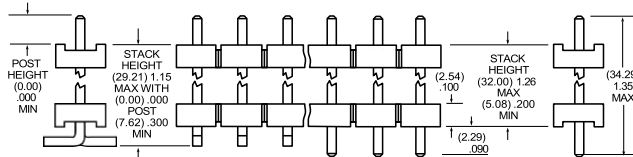

HPF	NO. OF PINS	LEAD STYLE	PLATING OPTION	S	OTHER OPTIONS
-----	-------------	------------	----------------	---	---------------

02 thru 20

01 = Through-hole
-02 = Surface Mount

-T = Matte Tin

-LC = Locking Clip (Manual placement required) (-02 lead style only)

-TR = Tape & Reel Packaging (14 positions max.) (Style -02 only)

-K = (6.50 mm) .256" DIA Polyimide film Pick & Place Pad

-FR = Full Reel Tape & Reel (must order max. quantity per reel; contact Samtec for quantity breaks) (14 positions max.) (Style -02 only)

